



# Mac Studio

## Apple Recycler Guide

May 2023

# Contents

3	<a href="#">About This Guide</a>
4	<a href="#">Identification</a>
5	<a href="#">Directive 2012/19/EU Annex VII Components</a>
6	<a href="#">Safety Considerations</a>
7	<a href="#">Recommended Tools</a>
8	<a href="#">Disassembly Instructions</a>
24	<a href="#">Material Categorization of Output Fractions</a>

# About This Guide

Apple Recycler Guides provide guidance for electronics recyclers on how to disassemble products to maximize recovery of resources. The guides provide step-by-step disassembly instructions and information on the material composition to help recyclers direct fractions to the appropriate material recycler.

To conserve important resources, we work to reduce the materials we use and aim to one day source only recycled or renewable materials in our products. A key path to reaching that goal is resource recovery from end-of-life electronics.

Disassembly procedures are intended to be performed only by trained electronics recycling professionals. The recycler is responsible for independently evaluating and ensuring compliance with all applicable environmental, health, and safety laws related to the work. These include but are not limited to laws relating to the management, handling, shipping, and disposal of the outputs of this work as waste and laws in place to ensure the health and safety of all employees who support this work.

For questions or feedback about this guide, email [contactesci@apple.com](mailto:contactesci@apple.com).

# Identification

You can find the model number on the bottom of the Mac.



*Model number:*  
A2615

# Directive 2012/19/EU Annex VII Components

Directive 2012/19/EU Annex VII requirements apply to the following substances and components.

<b>Substance/Component</b>	<b>Apple Part Name</b>	<b>Removal Instructions</b>
Printed circuit board if the surface is greater than 10 square centimeters	Power supply logic board, I/O board, main logic board	Follow steps 1–13
External electric cables	Power cord	Follow step 1
Battery	Coin cell battery	Follow steps 1–9
No further substances or components as listed in Annex VII		

# Safety Considerations

The recycler is responsible for independently evaluating all activities undertaken by its employees to perform or support the work and ensuring compliance with all applicable health and safety laws related to the work. These include but are not limited to laws relating to the health and safety of all employees who perform or support this work. The recycler is also responsible for evaluating the workspace and ensuring that the area in which the work is to be undertaken is designed using ergonomic best practices and meets all ergonomic requirements to ensure the protection of its employees.

## Personal Protective Equipment

Personal protective equipment should be worn during the entire recycling process.



Wear hand protection



Wear protective clothing



Wear eye protection



Wear foot protection

# Recommended Tools

Nail-pulling screwdriver

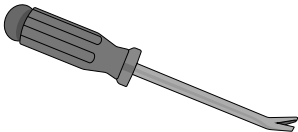

Torx T-3 screwdriver

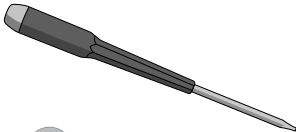

Torx T-5 screwdriver

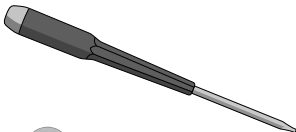

Torx T-6 screwdriver

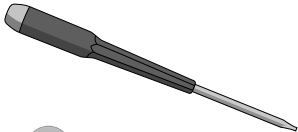

Torx T-8 screwdriver

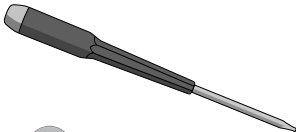

Torx T-10 screwdriver

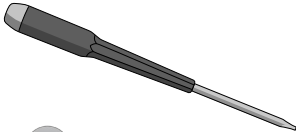

# Disassembly Instructions

## 1. Remove the power cord.

» *Ensure that the Mac Studio is turned off.*



» *Unplug the power cord from the back of the computer.*

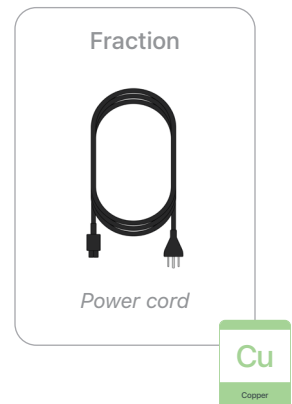

**Warning:** Before continuing disassembly, wait 10 minutes after unplugging the device for stored energy to discharge.



2. Pry the gasket off the bottom of the Mac Studio.

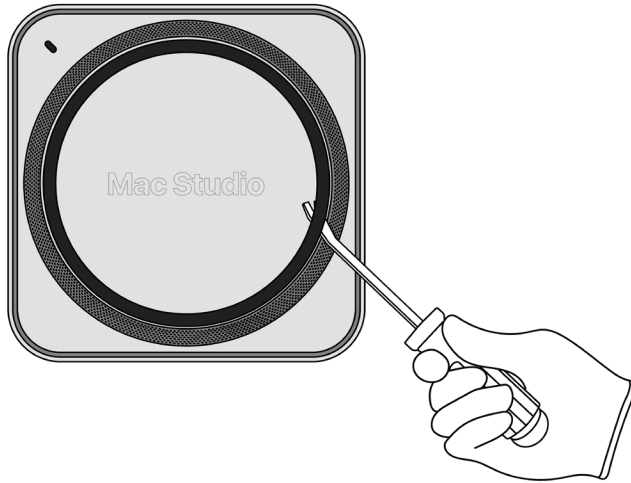

Tools Used

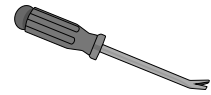

Fraction

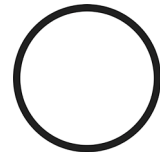

Gasket

PL

Plastics

### 3. Remove the bottom panel.

» Unscrew the four Torx T8 fasteners.

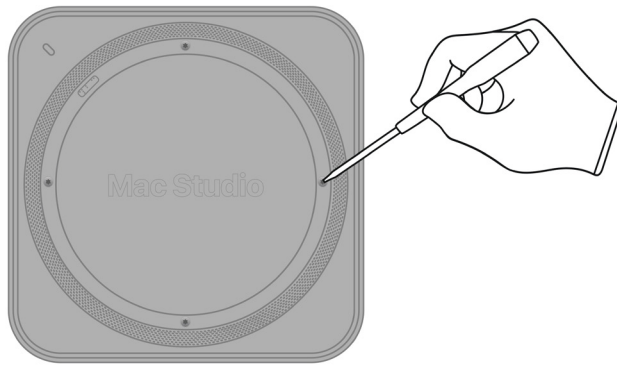

Tools Used

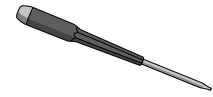

Fraction



Fasteners (x4)

Fe

Ferrous

» Pull off the bottom panel.

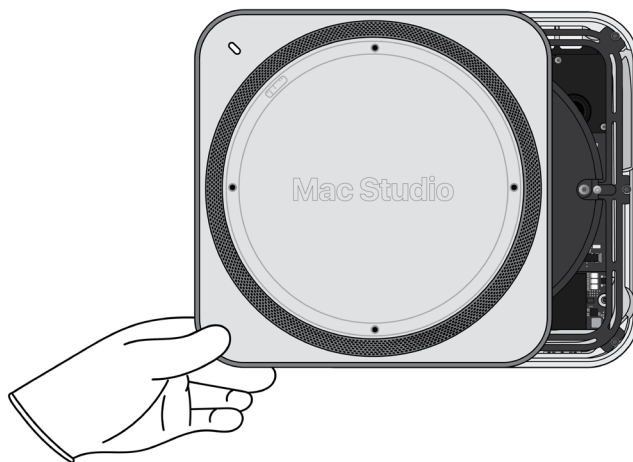

Fraction



Bottom panel

Al

Aluminum

## 4. Remove the power supply logic board.

» Unscrew the six Torx T10 fasteners.

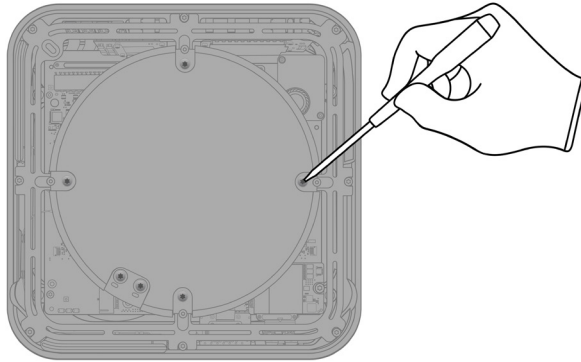

### Tools Used

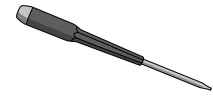

### Fraction



Fasteners (x6)

Fe

Ferrous

» Lift the power supply logic board out of the enclosure.

### Fraction

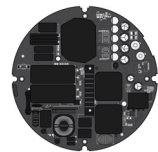

Power supply  
logic board

PMs

Precious  
Metals

5. Remove the frame by unscrewing the eight Torx T6 fasteners from the enclosure. Set the enclosure aside.

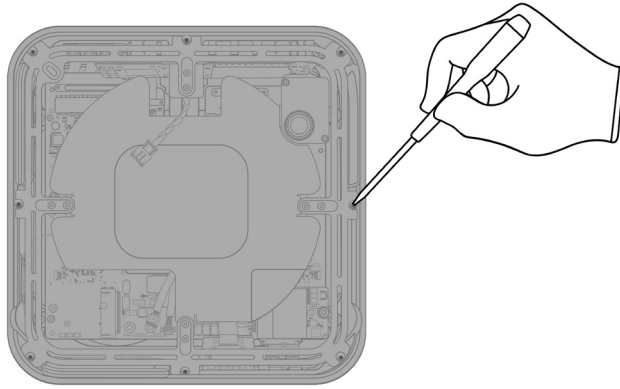

Tools Used

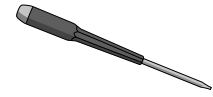

Fraction



Fasteners (x8)

Fe

Ferrous

6. Remove the heat shield from the frame by unscrewing the three Torx T6 fasteners.

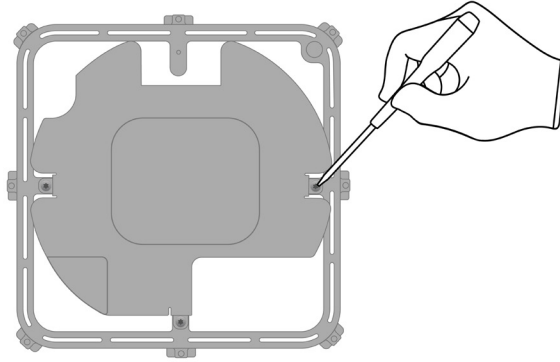

Tools Used

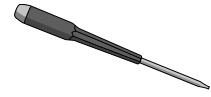

Fraction



Fasteners (x3)

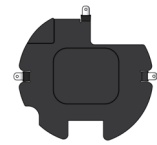

Heat shield

Fe

Ferrous

Fraction



Frame

Al

Aluminum

## 7. From the enclosure, remove the antennas.

» Unscrew the four Torx T5 fasteners from the antennas.

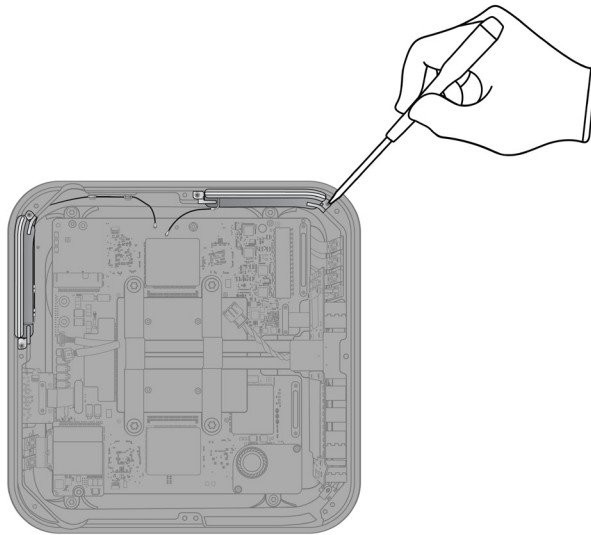

### Tools Used

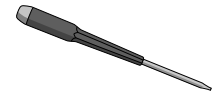

### Fraction



Fasteners (x4)

Fe

Ferrous

» Pull off both antennas by hand.

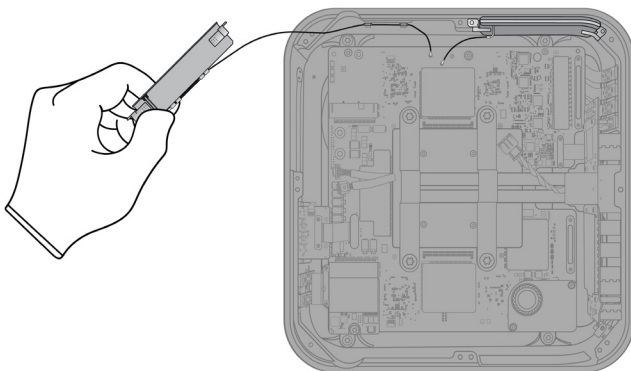

### Fraction

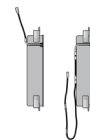

Antennas

Cu

Copper

8. Pry off the speaker.

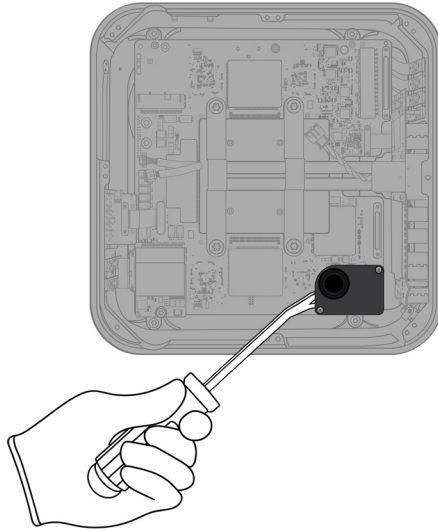

Tools Used

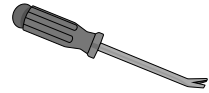

Fraction



Speaker



9. Remove the coin cell battery.

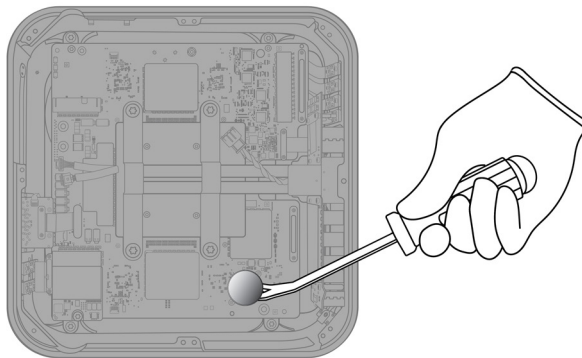

Tools Used

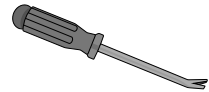

Fraction



Coin cell battery



- 10.** Remove the two brackets by unscrewing the four Torx T10 fasteners from the heat sink.

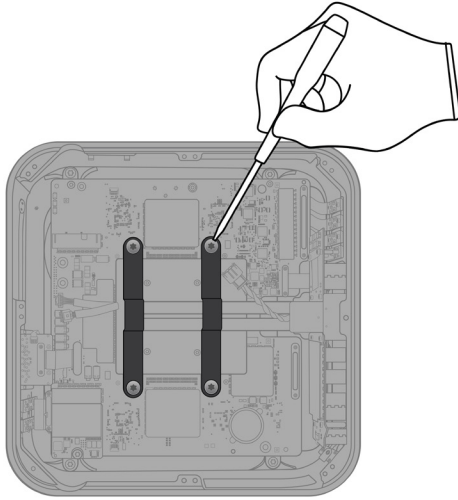

Tools Used

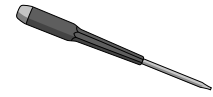

Fraction



Fasteners (x4)



Brackets

Fe

Ferrous



## 11. Remove the I/O board and the AC connector.

» Unscrew the seven Torx T3 fasteners from the I/O board.

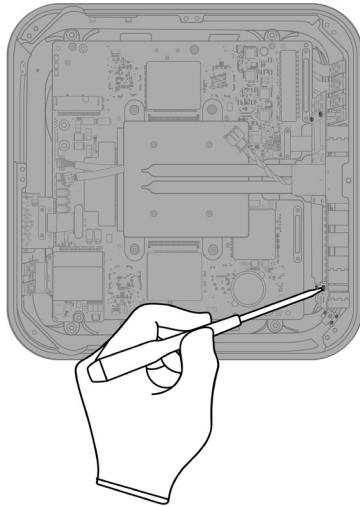

### Tools Used

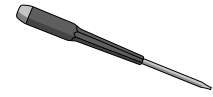

Torx T3

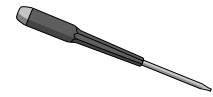

Torx T5

» Unscrew the 10 Torx T5 fasteners from the I/O board.

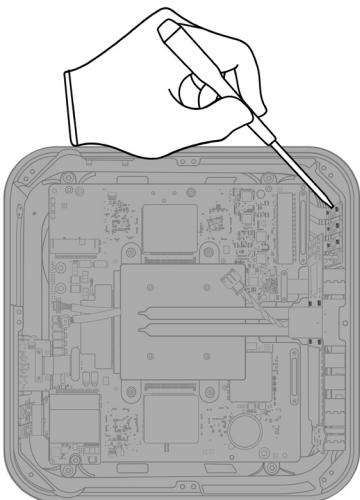

### Fraction



Fasteners (x17)

Fe

Ferrous

» Pull off the I/O board and the AC connector by hand.

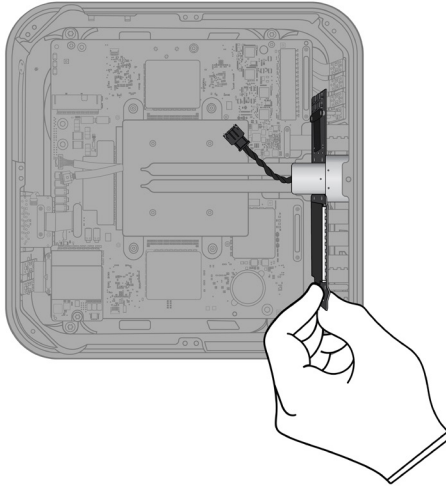

Fraction



I/O board

PMs  
Precious Metals

A box containing an illustration of the I/O board components, the text 'I/O board', and a green box with 'PMs' and 'Precious Metals' below it.

Fraction



AC connector

Cu  
Copper

A box containing an illustration of the AC connector, the text 'AC connector', and a green box with 'Cu' and 'Copper' below it.

**12.** Unscrew the four Torx T5 fasteners from the SD card reader and Thunderbolt 3 ports.

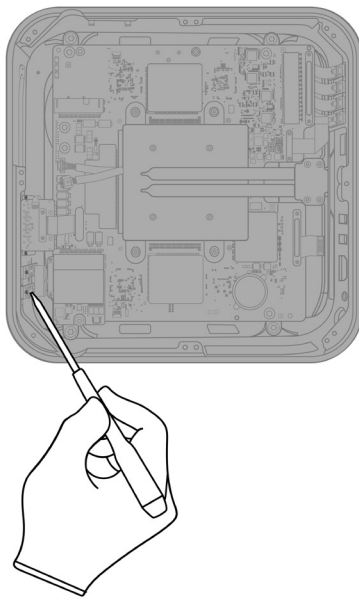

Tools Used

A simple illustration of a Torx T5 screwdriver.

Fraction



Fasteners (x4)

Fe  
Ferrous

A box containing an illustration of a Torx T5 fastener, the text 'Fasteners (x4)', and a green box with 'Fe' and 'Ferrous' below it.

## 13. Remove the main logic board.

- » *Unscrew the four Torx T8 fasteners from the main logic board.*

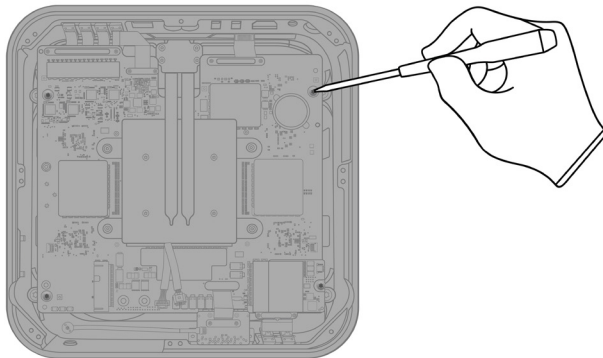

### Tools Used

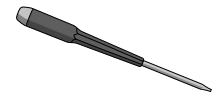

Torx T8

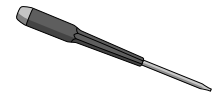

Torx T6

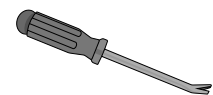

- » *Unscrew the four Torx T6 fasteners from the heat sink.*

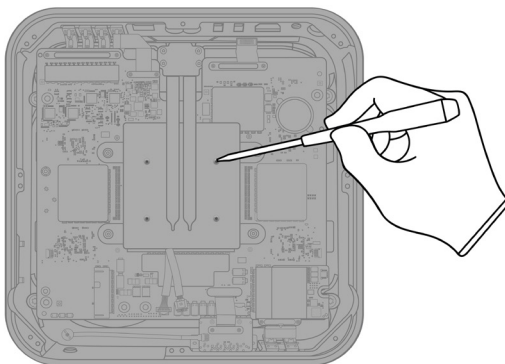

### Fraction



Fasteners (x8)

Fe

Ferrous

» Using the nail-pulling screwdriver, pry off the main logic board.

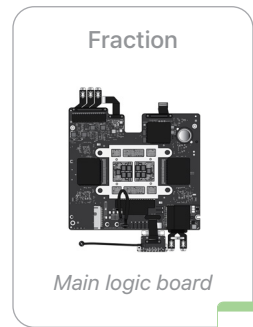
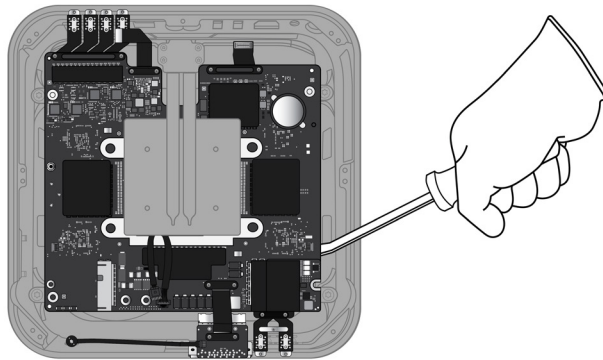

Fraction

Main logic board



**14.** Unscrew the four additional Torx T8 fasteners from the heat sink.

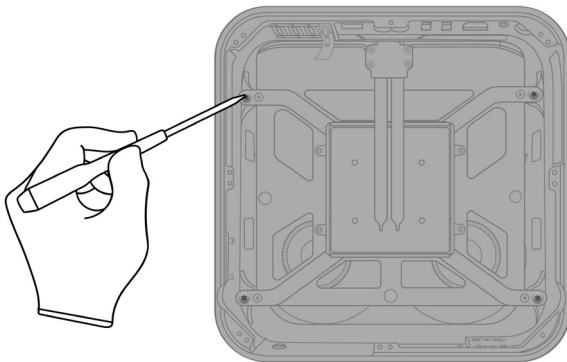

Tools Used



Fraction

Fasteners (x4)



**15.** Remove the Thunderbolt 3 port by unscrewing the two Torx T5 fasteners.

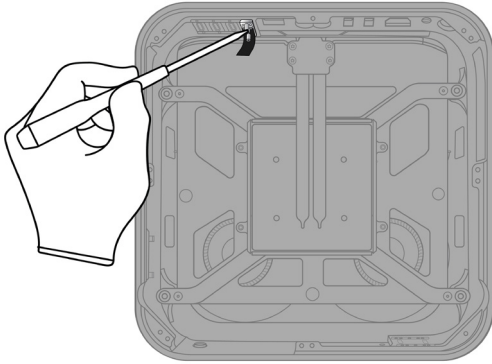

Tools Used

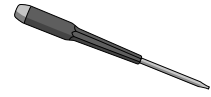

Fraction



Fasteners (x2)

Fe

Ferrous

Fraction



Thunderbolt 3 port

Cu

Copper

**16.** Pull the heat sink and dual fan out of the enclosure.

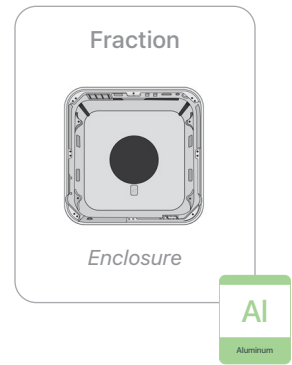
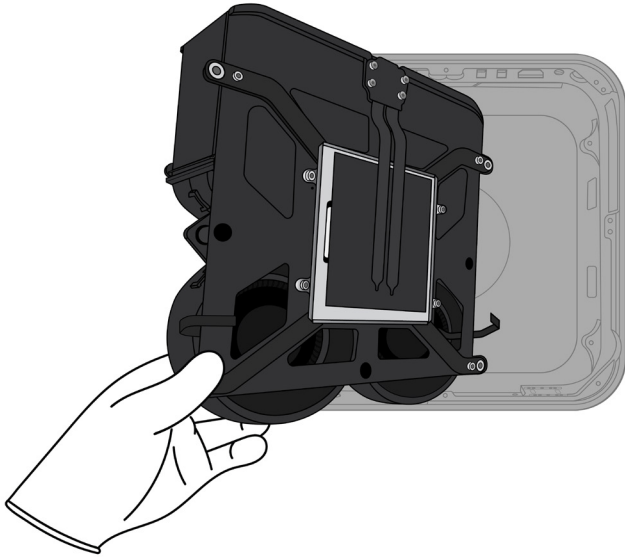

## 17. Separate the dual fan from the heat sink.

» Unscrew the two Torx T8 fasteners from the dual fan.

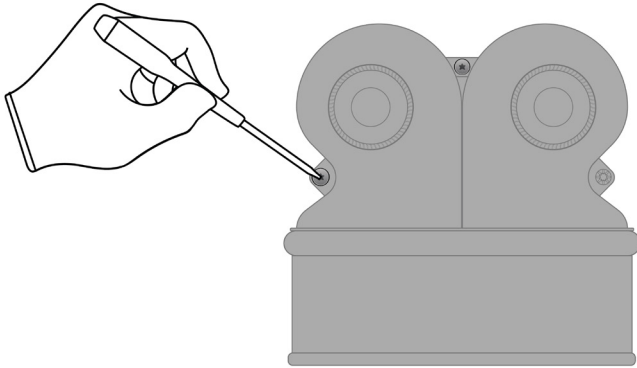

### Tools Used

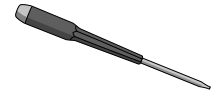

### Fraction



Fasteners (x2)

Fe

Ferrous

» Lift the dual fan off the heat sink.

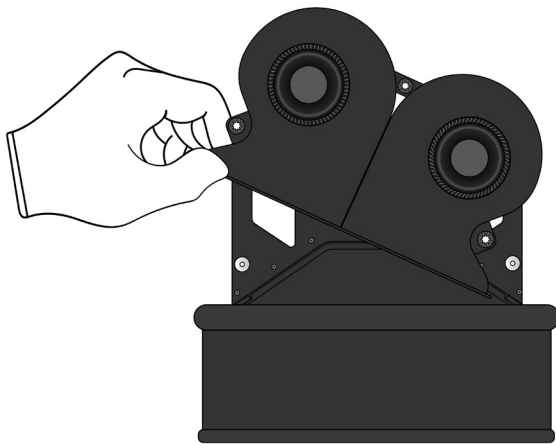

### Fraction



Dual fan

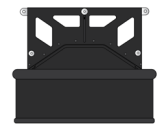

Heat sink

Cu

Copper

# Material Categorization of Output Fractions

All outputs from this process must be managed, handled, and disposed of in accordance with applicable waste laws and regulations, including but not limited to the Waste Framework Directive and its national enactments in Europe.

Fraction	Downstream Processing
----------	-----------------------

### Aluminum



Bottom panel



Frame



Enclosure

### Primary Target Material



### Potential Additional Materials



### Batteries



Coin cell battery

### Primary Target Material





**Fraction**

**Downstream Processing**

**Ferrous**



*Fasteners (x66)*



*Heat shield*

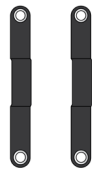

*Brackets*

**Primary Target Material**



**Potential Additional Materials**



**Logic Boards**

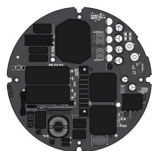

*Power supply logic board*



*I/O board*



*Main logic board*

**Primary Target Material**



**Potential Additional Materials**



**Fraction**

**Downstream Processing**

**Mixed Electronics**



*Power cord*

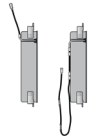

*Antennas*



*AC connector*



*Thunderbolt 3 port*



*Dual fan*

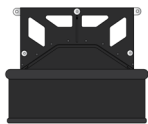

*Heat sink*

**Primary Target Material**



**Potential Additional Materials**



**Fraction**

**Downstream Processing**

**Mixed Plastics**

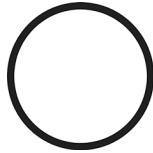

*Gasket*

**Primary Target Material**



**Rare Earth Magnets**



*Speaker*

**Primary Target Material**



**Potential Additional Materials**

